

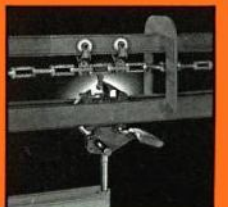

Rapid Industries, Inc.

DESIGNERS • MANUFACTURERS • INSTALLERS

Rapid Flex™ Enclosed Track Systems and Components

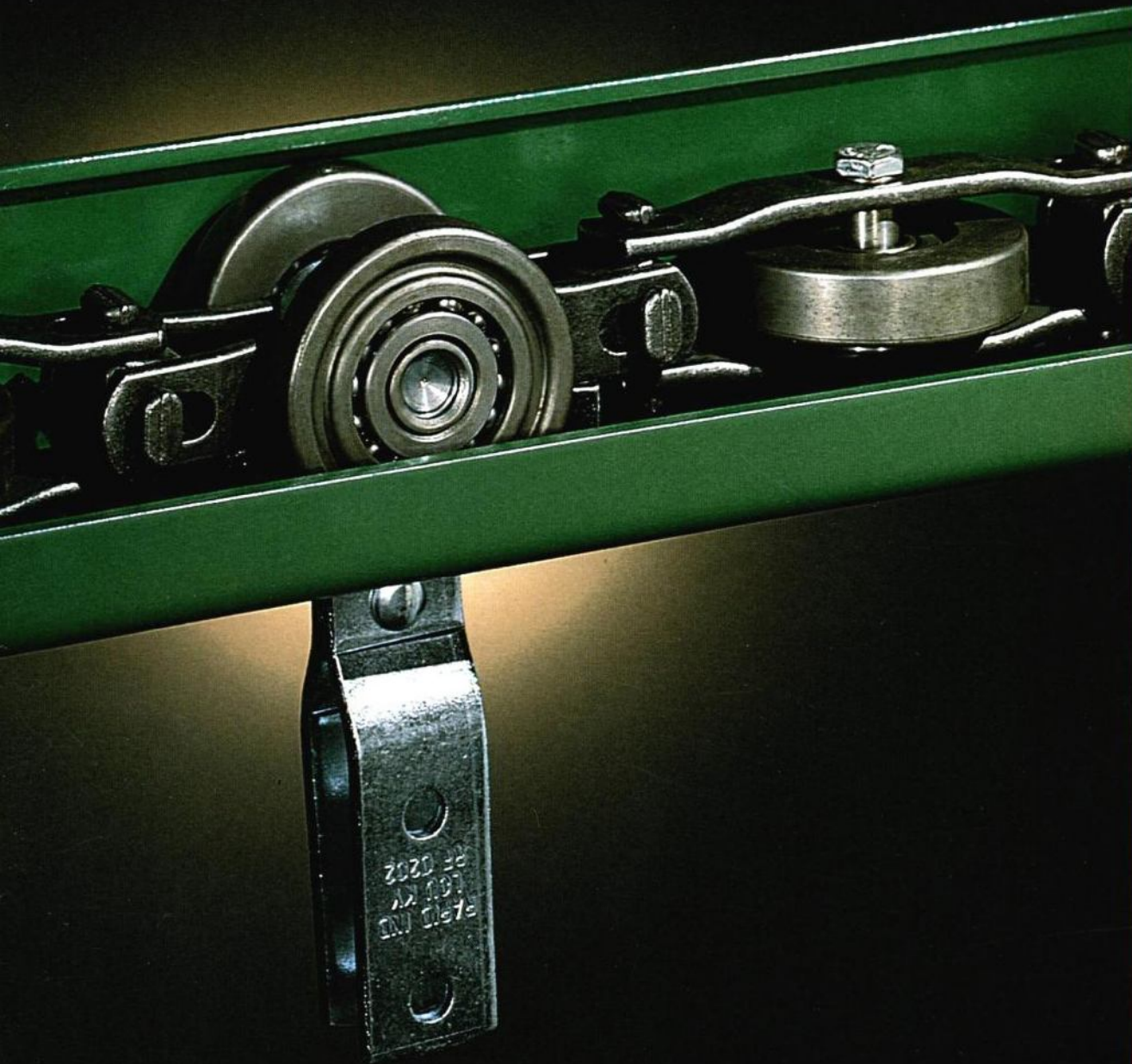



Rapid Flex™ Enclosed Track Overhead Conveyor

Rapid Flex™ Enclosed Track Overhead Conveyor

THE RAPID FLEX™ ENCLOSED TRACK OVERHEAD CONVEYOR, designed to complement our X-348 conveyor systems, is another excellent result of our efforts to provide manufacturers with better ways to move their product.

Among its many attractive features, the RAPID FLEX™ ENCLOSED TRACK SYSTEM incorporates reliability, economy, flexibility and ease of installation. It also eliminates the need for traction wheels on most horizontal turns and has the capability to be used in an over/under loop configuration, a 90° twist, or even a 90° vertical incline.

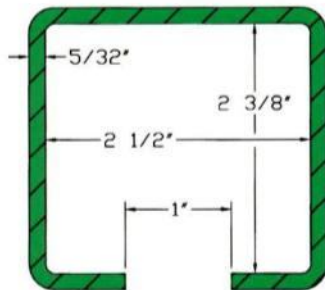

STRAIGHT TRACK SECTION
RF-0800 (WT. 5#/FT.)

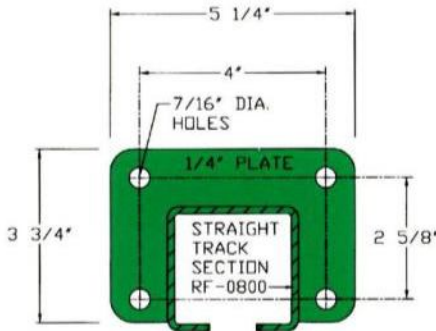

STRAIGHT TRACK SECTION WITH
RF-1913 END PLATE (SPECIAL ORDER)

Rapid Flex™ Enclosed Track

RAPID FLEX™ ENCLOSED TRACK is formed from high strength steel with a square cross-section as shown.

Our stock 20'-0" lengths may be saw cut and welded without special equipment. End plates may be supplied for bolted installation.

Our standard paint color is "RAPID GREEN". Other colors are available on request.

Rapid Flex™ Chain

RAPID FLEX™ CHAIN is designed for ultimate flexibility in every direction, yet is still stronger than the traditional link. This chain is made up of a series of alternating vertical wheels and lateral wheel units on 4" centers. RAPID FLEX™ CHAIN may be easily assembled using common hand tools.

Chain pull should be limited to 600 pounds per drive unit. This provides a 16 to 1 safety factor for maximum chain life.

RAPID FLEX™ CHAIN may be easily disassembled by removing the axle bolt in any side guide wheel and rotating the link 90°.

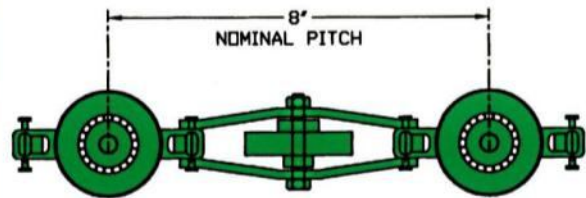

CHAIN ASSEMBLY
RF-0102-HEAVY DUTY (WT. 3.65#/FT.)

Rapid Flex™ Heavy Duty Load Wheel

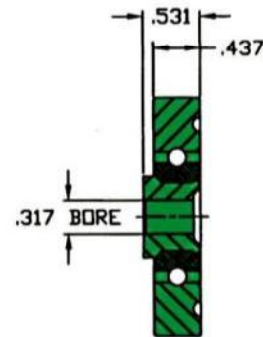

Rapid Flex™ Heavy Duty Guide Wheels

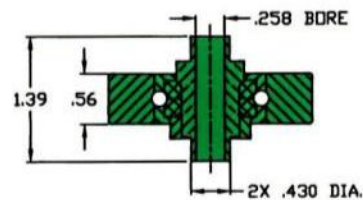

RAPID FLEX™ HEAVY DUTY WHEELS are ball bearing style, made of machined steel with machined ball bearing races. Heat-treated steel balls are used. All wheel parts are heat-treated to provide maximum life.

Rapid Flex™ Universal Link Chain

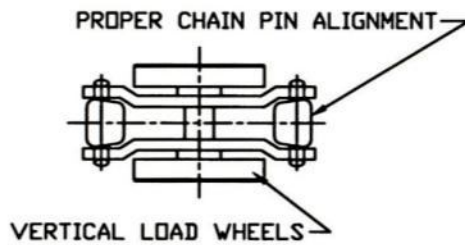

Note: The universal pins must be in the proper position. If one is backwards, the chain may not pass through the drive.

Assembly/Disassembly

To disassemble Rapid Flex™ chain, perform the following:

Step A

Remove the bolt (item 1) from the side guide wheel (item 2).

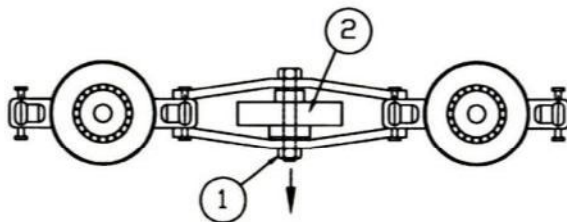

Step B

Turn the load wheel (item 5) 90° to the side guide wheel assembly (item 2).

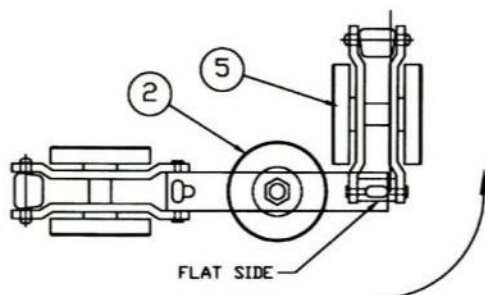

Step C

Remove side links (item 4) and side guide wheel (item 2).

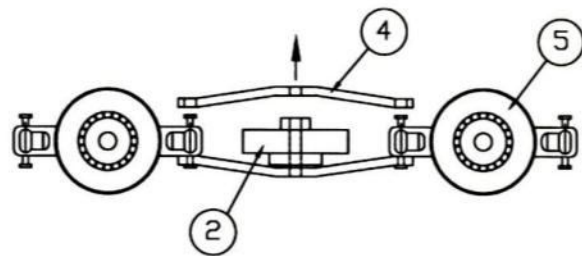

Step D

To assemble Rapid Flex™ chain, follow the disassembly procedure in reverse order. When assembling chain, make sure the flat face of the 4-way pin is facing the side guide wheel.

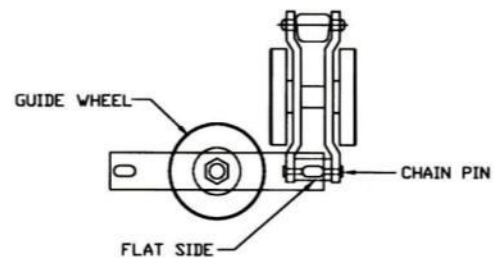

After assembly, distort the threads on the side guide wheel bolt by peening the end of the bolt. This will prevent the nut from loosening and coming off.



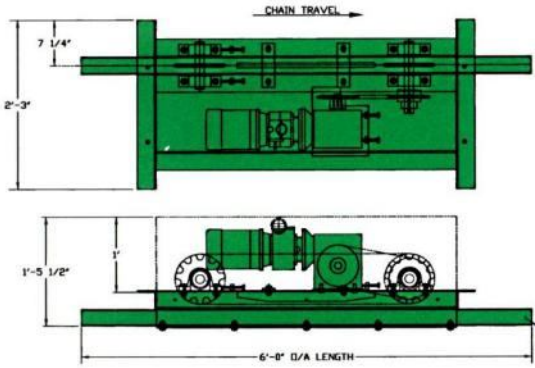

RF-1701 CONSTANT SPEED Drive Unit
RF-1702 VARIABLE SPEED Drive Unit

Rapid Flex™ Caterpillar Drive Unit

RAPID FLEX™ CATERPILLAR DRIVES allow maximum drive location flexibility and offer many unique features which make this drive unchallenged in its class.

Constant or variable speed is available. Standard variable speed ratio is 3 to 1. Overload protection is supplied on all drives.

Combination right angle helical worm reducers provide efficient power transfer. Fixed caterpillar drive dogs are heat treated for added strength and wearability.

Drive chain and guards are supplied with each drive unit.

Drive frame and track are painted "RAPID GREEN". Other colors are available upon request.

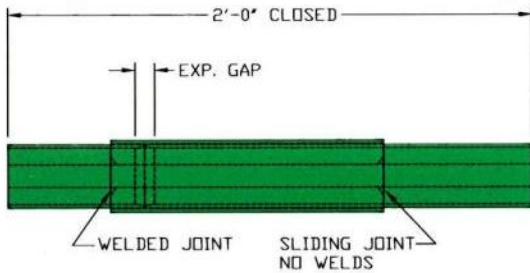

RF-0900

Rapid Flex™ Oven Expansion Joint

Formed metal sliding expansion joints are available for oven conveyors and are usually required where temperatures exceed 200° F.

Rate of expansion of track in ovens: 0.000078" per foot of length for 1° F of temperature rise.

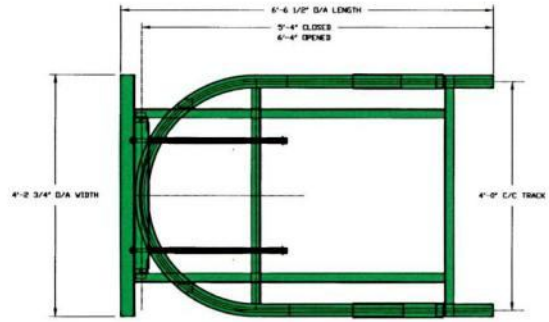

RF-1600

Rapid Flex™ Take-Up Unit

RAPID FLEX™ TAKE-UPS maintain proper chain tension and are required on every powered system.

Chain stretch will occur due to normal usage of the system. Chain expansion will occur if operating in dry off or bake ovens.

Take-ups are available in three styles with manual screw adjustable and automatic spring adjustable being the most common.

For air operated take-up units, air pressure above 20 p.s.i.g. may be detrimental to system.

Our standard units are 2'-0" radius (4'-0" spread); however, other widths are also available.

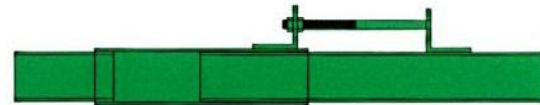

RF-1601

Rapid Flex™ Take-Up Expansion Joint

Formed metal sliding expansion joints with screw adjusters are available for field erected take-up units.

Rapid Flex™ Clevis & Safety Pin

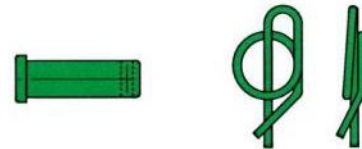

RF-0200

5/16" x 1-1/4" Clevis & Safety Pin for Attachments

RF-0300

3/8" x 1-1/4" Clevis & Safety Pin for Load Bar

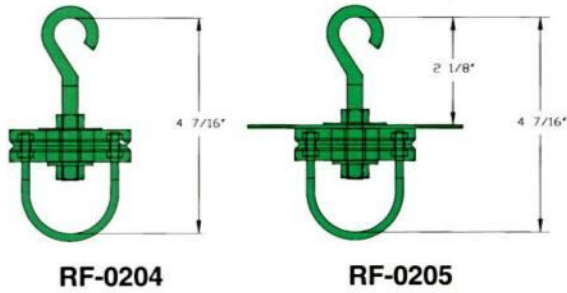

RF-0204

RF-0205

Rapid Flex™ Swivel Rotator

This free spinning, ball bearing swivel assembly can be rotated by hand or automatically rotated at any point in the system with the installation of a rub rail. With the addition of a 6 point star, positive rotation is provided.

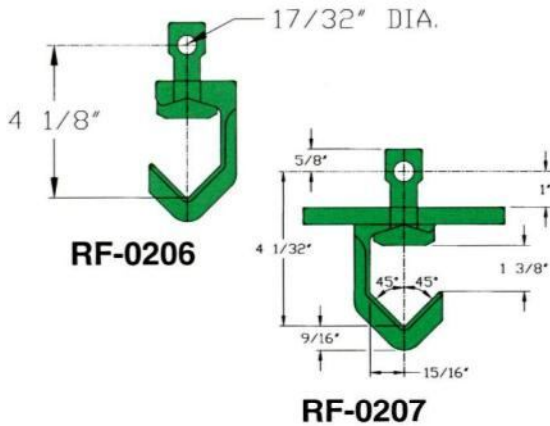

RF-0206

RF-0207

Rapid Flex™ 90° Indexing Hook

Cast 2 piece cam construction provides positive 90° indexing. The standard hook with 4-point star allows automatic indexing.

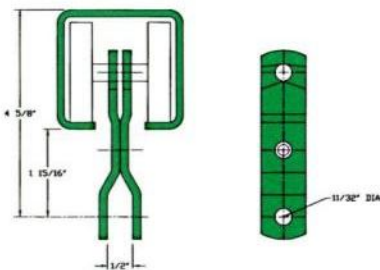

RF-0201

Rapid Flex™ Standard "H" Attachments (Capacity 75 lbs.)

The standard "H" attachment attaches directly to the chain load wheel axle. The scissor like action allows for easy installation anywhere on the line and is locked into position by the carrier clevis bolt.

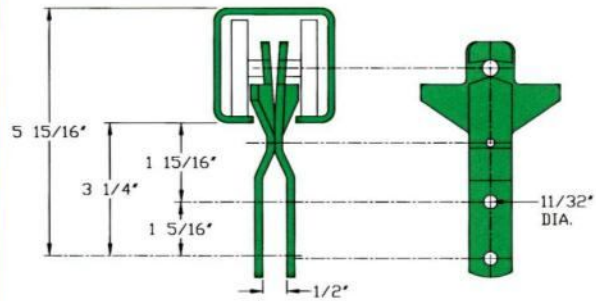

RF-0202

Rapid Flex™ Rigid "H" Attachment (Capacity 75 lbs.)

This attachment remains perpendicular to the chain at all times. The additional clevis hole allows the carrier to also be fixed in a rigid position.

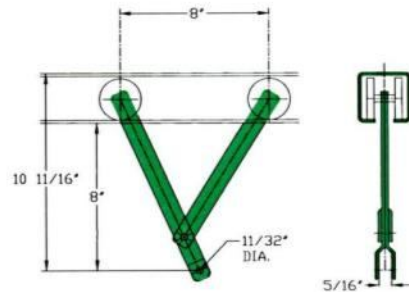

RF-0203

Rapid Flex™ Extended "H" Attachment (Capacity 75 lbs., Minimum Radius 24")

This attachment is primarily used on conveyors with vertical travel to hold the load or carrier away from the track.

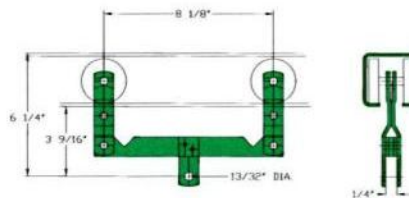

RF-0301

Rapid Flex™ Load Bar (Capacity 150 lbs.)

To increase the load capacity up to 150 lbs., a load bar is suspended from two "H" attachments.





Rapid Flex™ Vertical Curves

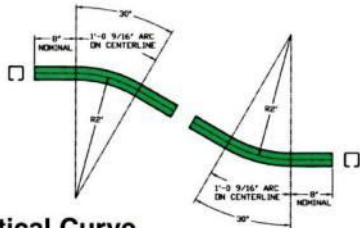

Upper Vertical Curve
2'-0" Rad. 30°
RF-0504

Lower Vertical Curve
2'-0" Rad. 30°
RF-0604

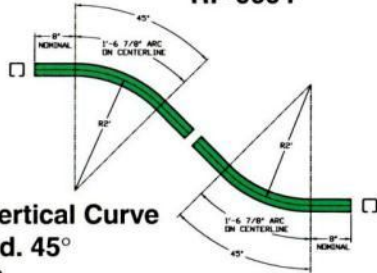

Upper Vertical Curve
2'-0" Rad. 45°
RF-0503

Lower Vertical Curve
2'-0" Rad. 45°
RF-0603

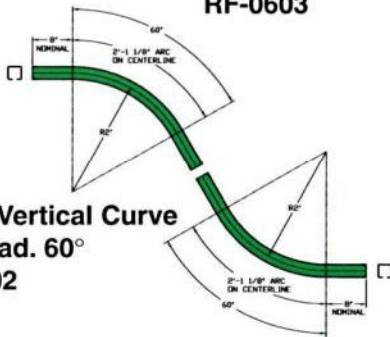

Upper Vertical Curve
2'-0" Rad. 60°
RF-0502

Lower Vertical Curve
2'-0" Rad. 60°
RF-0602

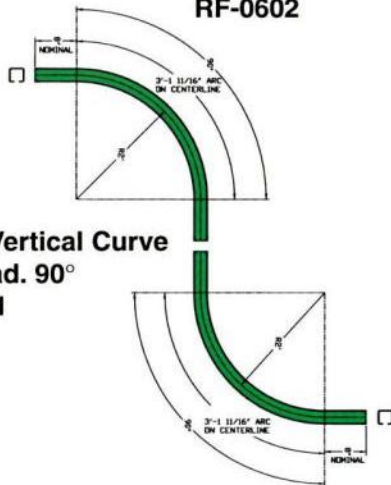

Upper Vertical Curve
2'-0" Rad. 90°
RF-0501

Lower Vertical Curve
2'-0" Rad. 90°
RF-0601

Upper and lower Vertical Curves, as illustrated above, are carried in stock. However, special radius or degree curves can be fabricated on order. See reference vertical chart on page 7.

Rapid Flex™ Horizontal Turns

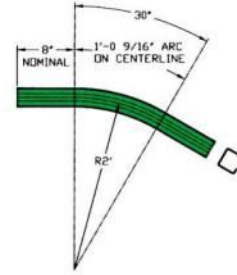

2'-0" Rad. 30° Horizontal Turn
RF-0404

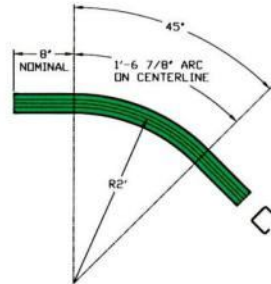

2'-0" Rad. 45° Horizontal Turn
RF-0403

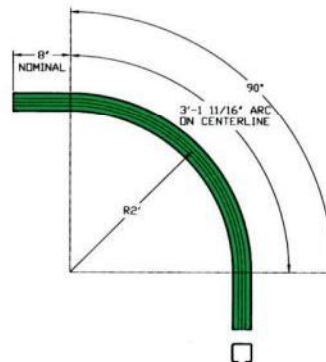

2'-0" Rad. 90° Horizontal Turn
RF-0402

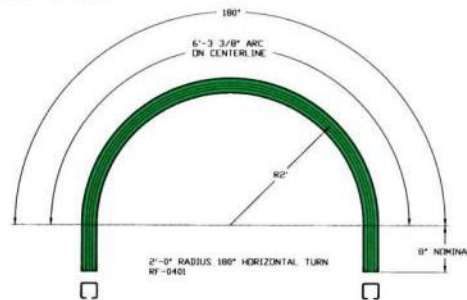

2'-0" Rad. 180° Horizontal Turn
RF-0401

Horizontal Turns, as illustrated above, are carried in stock. However, special radius or degree turns can be fabricated on order. For less than 24" radius special traction wheels can be supplied to a minimum of 12" radius with conventional bearings or metalized graphite bushings for high temperature applications. Note: Straight after Tangent may vary from 8".

Vertical Curves

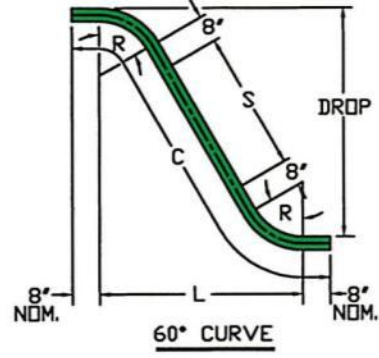
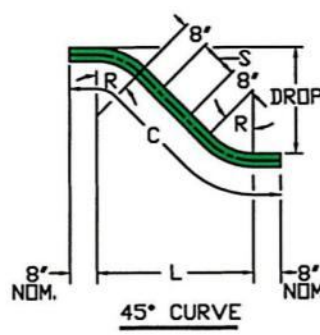
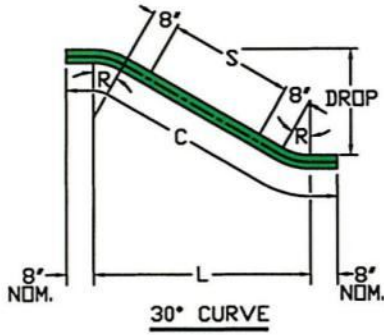

2'-0" RADIUS X 30 DEGREES			
DROP	"C"	"L"	"S"
1'-2 3/8"	4'-9 1/8"	3'-1 7/8"	0'-0"
1'-6"	5'-4 1/4"	3'-8"	0'-7 1/8"
1'-9"	5'-10 1/4"	4'-1 1/4"	1'-1 1/8"
2'-0"	6'-4 1/4"	4'-6 3/8"	1'-7 1/8"
2'-3"	6'-10 1/4"	4'-11 5/8"	2'-1 1/8"
2'-6"	7'-4 1/4"	5'-4 7/8"	2'-7 1/8"
2'-9"	7'-10 1/4"	5'-10"	3'-1 1/8"
3'-0"	8'-4 1/4"	6'-3 1/4"	3'-7 1/8"
3'-6"	9'-4 1/4"	7'-1 5/8"	4'-7 1/8"
4'-0"	10'-4 1/4"	8'-0"	5'-7 1/8"
4'-6"	11'-4 1/4"	8'-10 3/8"	6'-7 1/8"
5'-0"	12'-4 1/4"	9'-8 3/4"	7'-7 1/8"
5'-6"	13'-4 1/4"	10'-7 1/8"	8'-7 1/8"
6'-0"	14'-4 1/4"	11'-5 5/8"	9'-7 1/8"
6'-6"	15'-4 1/4"	12'-4"	10'-7 1/8"
7'-0"	16'-4 1/4"	13'-2 3/8"	11'-7 1/8"
7'-6"	17'-4 1/4"	14'-0 3/4"	12'-7 1/8"
8'-0"	18'-4 1/4"	14'-11 1/8"	13'-7 1/8"
8'-6"	19'-4 1/4"	15'-9 1/2"	14'-7 1/8"
9'-0"	20'-4 1/4"	16'-7 7/8"	15'-7 1/8"
9'-6"	21'-4 1/4"	17'-6 3/8"	16'-7 1/8"
10'-0"	22'-4 1/4"	18'-4 3/4"	17'-7 1/8"
10'-6"	23'-4 1/4"	19'-3 1/8"	18'-7 1/8"
11'-0"	24'-4 1/4"	20'-1 1/2"	19'-7 1/8"
11'-6"	25'-4 1/4"	20'-11 7/8"	20'-7 1/8"
12'-0"	26'-4 1/4"	21'-10 1/4"	21'-7 1/8"
12'-6"	27'-4 1/4"	22'-8 5/8"	22'-7 1/8"

2'-0" RADIUS X 45 DEGREES			
DROP	"C"	"L"	"S"
2'-1 3/8"	5'-9 3/4"	3'-9 1/4"	0'-0"
2'-3"	6'-0"	3'-10 7/8"	0'-2 1/4"
2'-6"	6'-4 1/4"	4'-1 7/8"	0'-6 1/2"
2'-9"	6'-8 1/2"	4'-4 7/8"	0'-10 3/4"
3'-0"	7'-0 3/4"	4'-7 7/8"	1'-3"
3'-6"	7'-9 1/4"	5'-1 7/8"	1'-11 1/2"
4'-0"	8'-5 3/4"	5'-7 7/8"	2'-8"
4'-6"	9'-2 1/8"	6'-1 7/8"	3'-4 1/2"
5'-0"	9'-10 5/8"	6'-7 7/8"	4'-1"
5'-6"	10'-7 1/8"	7'-1 7/8"	4'-9 1/2"
6'-0"	11'-3 5/8"	7'-7 7/8"	5'-6"
6'-6"	12'-0 1/8"	8'-1 7/8"	6'-2 3/8"
7'-0"	12'-8 5/8"	8'-7 7/8"	6'-10 7/8"
7'-6"	13'-5 1/8"	9'-1 7/8"	7'-7 3/8"
8'-0"	14'-1 5/8"	9'-7 7/8"	8'-3 7/8"
8'-6"	14'-10 1/8"	10'-1 7/8"	9'-0 3/8"
9'-0"	15'-6 1/2"	10'-7 7/8"	9'-8 7/8"
9'-6"	16'-3"	11'-1 7/8"	10'-5 3/8"
10'-0"	16'-11 1/2"	11'-7 7/8"	11'-1 7/8"
10'-6"	17'-8"	12'-1 7/8"	11'-10 1/4"
11'-0"	18'-4 1/2"	12'-7 7/8"	12'-6 3/4"
11'-6"	19'-1"	13'-1 7/8"	13'-3 1/4"
12'-0"	19'-9 1/2"	13'-7 7/8"	13'-11 3/4"
12'-6"	20'-6"	14'-1 7/8"	14'-8 1/4"

2'-0" RADIUS X 60 DEGREES			
DROP	"C"	"L"	"S"
3'-1 7/8"	6'-10 1/4"	4'-1 5/8"	0'-0"
3'-6"	7'-3"	4'-4"	0'-4 3/4"
4'-0"	7'-10"	4'-7 3/8"	0'-11 3/4"
4'-6"	8'-4 7/8"	4'-10 7/8"	1'-6 5/8"
5'-0"	8'-11 7/8"	5'-2 3/8"	2'-1 5/8"
5'-6"	9'-6 3/4"	5'-5 7/8"	2'-8 1/2"
6'-0"	10'-1 3/4"	5'-9 1/4"	3'-3 3/8"
6'-6"	10'-8 5/8"	6'-0 3/4"	3'-10 3/8"
7'-0"	11'-3 1/2"	6'-4 1/4"	4'-5 1/4"
7'-6"	11'-10 1/2"	6'-7 5/8"	5'-0 1/4"
8'-0"	12'-5 3/8"	6'-11 1/8"	5'-7 1/8"
8'-6"	13'-0 3/8"	7'-2 5/8"	6'-2 1/8"
9'-0"	13'-7 1/4"	7'-6 1/8"	6'-9"
9'-6"	14'-2 1/4"	7'-9 1/2"	7'-3 7/8"
10'-0"	14'-9 1/8"	8'-1"	7'-10 7/8"
10'-6"	15'-4"	8'-4 1/2"	8'-5 3/4"
11'-0"	15'-11"	8'-7 7/8"	9'-0 3/4"
11'-6"	16'-5 7/8"	8'-11 3/8"	9'-7 5/8"
12'-0"	17'-0 7/8"	9'-2 7/8"	10'-2 5/8"
12'-6"	17'-7 3/4"	9'-6 3/8"	10'-9 1/2"

3'-0" RADIUS X 30 DEGREES			
DROP	"C"	"L"	"S"
1'-5 5/8"	5'-9 3/4"	4'-1 7/8"	0'-0"
1'-9"	6'-4 3/8"	4'-7 5/8"	0'-6 3/4"
2'-0"	6'-10 3/8"	5'-0 7/8"	1'-0 3/4"
2'-3"	7'-4"	5'-6"	1'-6 3/4"
2'-6"	7'-10 3/8"	5'-11 1/4"	2'-0 3/4"
2'-9"	8'-4 3/8"	6'-4 1/2"	2'-6 3/4"
3'-0"	8'-10 3/8"	6'-9 5/8"	3'-0 3/4"
3'-6"	9'-10 3/8"	7'-8"	4'-0 3/4"
4'-0"	10'-10 3/8"	8'-6 3/8"	5'-0 3/4"
4'-6"	11'-10 3/8"	9'-4 7/8"	6'-0 3/4"
5'-0"	12'-10 3/8"	10'-3 1/4"	7'-0 3/4"
5'-6"	13'-10 3/8"	11'-1 5/8"	8'-0 3/4"
6'-0"	14'-10 3/8"	12'-0"	9'-0 3/4"
6'-6"	15'-10 3/8"	12'-10 3/8"	10'-0 3/4"
7'-0"	16'-10 3/8"	13'-8 3/4"	11'-0 3/4"
7'-6"	17'-10 3/8"	14'-7 1/8"	12'-0 3/4"
8'-0"	18'-10 3/8"	15'-5 5/8"	13'-0 3/4"
8'-6"	19'-10 3/8"	16'-4"	14'-0 3/4"
9'-0"	20'-10 3/8"	17'-2 3/8"	15'-0 3/4"
9'-6"	21'-10 3/8"	18'-0 3/4"	16'-0 3/4"
10'-0"	22'-10 3/8"	18'-11 1/8"	17'-0 3/4"
10'-6"	23'-10 3/8"	19'-9 1/2"	18'-0 3/4"
11'-0"	24'-10 3/8"	20'-7 7/8"	19'-0 3/4"
11'-6"	25'-10 3/8"	21'-6 3/8"	20'-0 3/4"
12'-0"	26'-10 3/8"	22'-4 3/4"	21'-0 3/4"
12'-6"	27'-10 3/8"	23'-3 1/8"	22'-0 3/4"

3'-0" RADIUS X 45 DEGREES			
DROP	"C"	"L"	"S"
2'-8 3/8"	7'-4 1/2"	5'-2 1/4"	0'-0"
3'-0"	7'-9 5/8"	5'-5 7/8"	0'-5 1/8"
3'-6"	8'-6 1/8"	5'-11 7/8"	1'-1 5/8"
4'-0"	9'-2 5/8"	6'-5 7/8"	1'-10"
4'-6"	9'-11 1/8"	6'-11 7/8"	2'-6 1/2"
5'-0"	10'-7 5/8"	7'-5 7/8"	3'-3"
5'-6"	11'-4 1/8"	7'-11 7/8"	3'-11 1/2"
6'-0"	12'-0 1/2"	8'-5 7/8"	4'-8"
6'-6"	12'-9"	8'-11 7/8"	5'-4 1/2"
7'-0"	13'-5 1/2"	9'-5 7/8"	6'-1"
7'-6"	14'-2"	9'-11 7/8"	6'-9 1/2"
8'-0"	14'-10 1/2"	10'-5 7/8"	7'-6"
8'-6"	15'-7"	10'-11 7/8"	8'-2 3/8"
9'-0"	16'-3 1/2"	11'-5 7/8"	8'-10 7/8"
9'-6"	17'-0"	11'-11 7/8"	9'-7 3/8"
10'-0"	17'-8 3/8"	12'-5 7/8"	10'-3 7/8"
10'-6"	18'-4 7/8"	12'-11 7/8"	11'-0 3/8"
11'-0"	19'-1 3/8"	13'-5 7/8"	11'-8 7/8"
11'-6"	19'-9 7/8"	13'-11 7/8"	12'-5 3/8"
12'-0"	20'-6 3/8"	14'-5 7/8"	13'-1 7/8"
12'-6"	21'-2 7/8"	14'-11 7/8"	13'-10 1/4"

3'-0" RADIUS X 60 DEGREES			
DROP	"C"	"L"	"S"
4'-1 7/8"	8'-11 3/8"	5'-10 3/8"	0'-0"
4'-6"	9'-4 1/8"	6'-0 3/4"	0'-4 3/4"
5'-0"	9'-11 1/8"	6'-4 1/4"	0'-11 3/4"
5'-6"	10'-6"	6'-7 5/8"	1'-6 5/8"
6'-0"	11'-1"	6'-11 1/8"	2'-1 5/8"
6'-6"	11'-7 7/8"	7'-2 5/8"	2'-8 1/2"
7'-0"	12'-2 7/8"	7'-6 1/8"	3'-3 3/8"
7'-6"	12'-9 3/4"	7'-9 1/2"	3'-10 3/8"
8'-0"	13'-4 5/8"	8'-1"	4'-5 1/4"
8'-6"	13'-11 5/8"	8'-4 1/2"	5'-0 1/4"
9'-0"	14'-6 1/2"	8'-7 7/8"	5'-7 1/8"
9'-6"	15'-1 1/2"	8'-11 3/8"	6'-2 1/8"
10'-0"	15'-8 3/8"	9'-2 7/8"	6'-9"
10'-6"	16'-3 3/8"	9'-6 3/8"	7'-3 7/8"
11'-0"	16'-10 1/4"	9'-9 3/4"	7'-10 7/8"
11'-6"	17'-5 1/8"	10'-1 1/4"	8'-5 3/4"
12'-0"	18'-0 1/8"	10'-4 3/4"	9'-0 3/4"
12'-6"	18'-7"	10'-8 1/8"	9'-7 5/8"

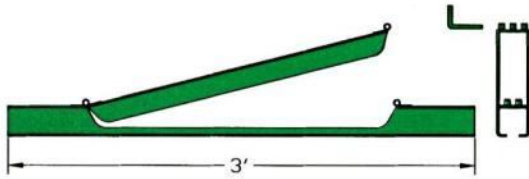

RF-1000

Rapid Flex™ Chain Inspection Gate

The track section with hinged panel is designed for chain inspection and maintenance.

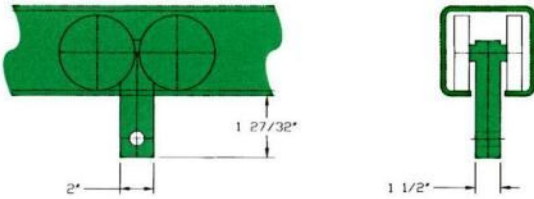

RF-2100

Rapid Flex™ 4-Wheel Pusher Dog/Chain Attachment

RAPID FLEX™ 4-WHEEL PUSHER DOG/CHAIN ATTACHMENT may be built into RAPID FLEX™ CHAIN for heavy load carrying applications. (Capacity 250 lbs.)

With RAPID FLEX™ POWER & FREE SYSTEMS this unit is used to provide the means to transfer power from the chain to the free trolleys.

This assembly includes heavy duty wheels and a high wearability "tooth" or "dog" in one easy to attach assembly.

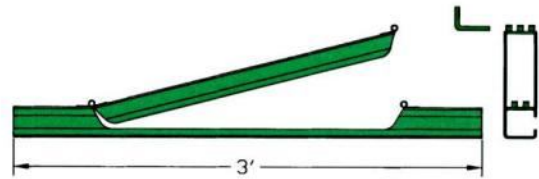

RF-1100

Rapid Flex™ Chain Installation Gate

This track section is supplied for ease of chain installation and removal. At least one installation gate is required on every system.

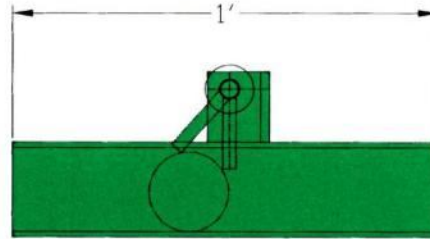

RF-1200

Rapid Flex™ Anti-Backup Safety Stop

Anti-backup safety stops are recommended on all loaded inclines in case of chain failure. These stops will prevent the run-away action caused by a loose chain.

Anti-backup safety stops are premounted to standard track sections. These units should be mounted on vertical curves near the bottom and every 10'-0" of incline on vertical curves with over 5'-0" drop.

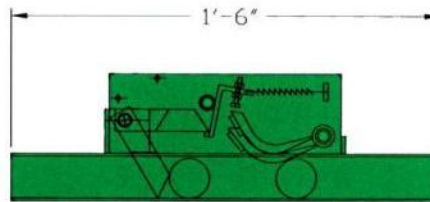

RF-1300

Rapid Flex™ Anti-Runaway Safety Stop

Anti-runaway safety stops are recommended on any loaded decline of approx. 5'-0" drop or more. The stop is activated by the conveyor chain accelerating beyond its design speed. These units are premounted to a standard track section.

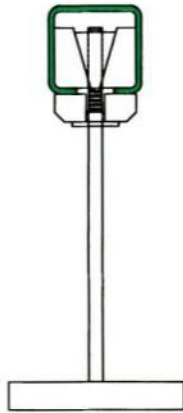

RF-1500

Rapid Flex™ Welding Fixture

RAPID FLEX™ WELDING FIXTURE insures a smooth, continuous, perfectly aligned track section and is recommended for all welded track joints on RAPID FLEX™ systems.

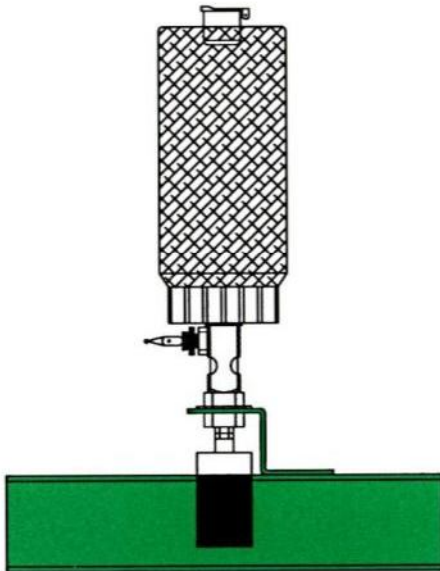

RF-1402 AUTOMATIC Brush-Type
RF-1403 MANUAL Brush-Type

Rapid Flex™ Chain Lubricators

RAPID FLEX™ CHAIN LUBRICATORS add dependability, smooth operation and extended life to your RAPID FLEX™ SYSTEM.

Rapid Flex™ Brush Type Chain Oiler

Two models are available - electric solenoid or manually controlled.

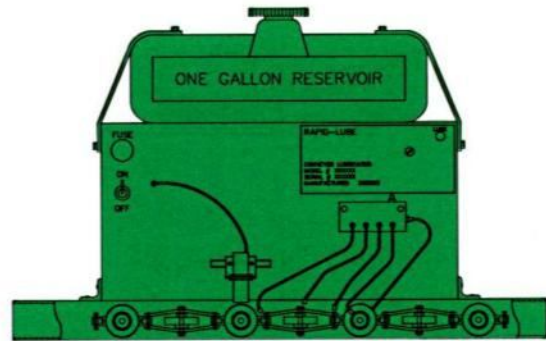

Automatic Lubricators

Designed to deliver metered amounts of lubricant directly to the chain wheels and connecting links.

Important Note: Systems in environments above ambient temperatures typically require continuous lubrication for reasonable chain life. Chain should never be idle while in high temperatures. (Automatic Lubricators are recommended for oven applications).

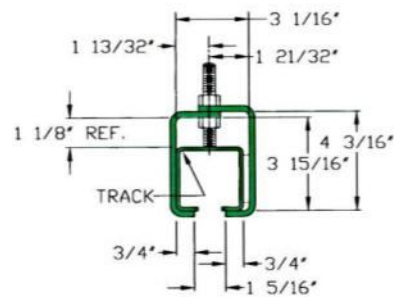

RF-1903

Rapid Flex™ Track Hanger Clamp (WT.1.5#)

Track Hanger Clamps are one method of supporting RAPID FLEX™ systems. These use a 1/2" diameter rod for support.



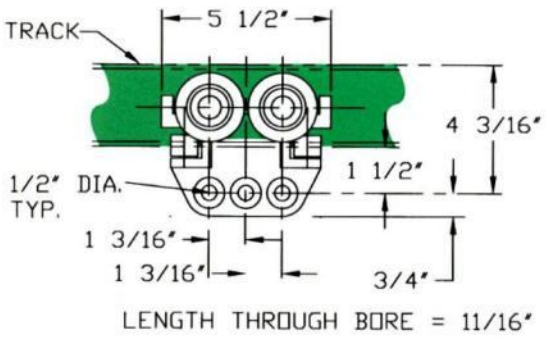

RF-2000 HAND PUSHED TROLLEY
(Capacity 250 Lbs./Heavy Duty Wheels)

Rapid Flex™ Hand Pushed Trolley Assembly

Four load wheels with hardened races and two hardened side guide rollers mounted to a one piece, high strength cast body provide long trolley life under adverse conditions.

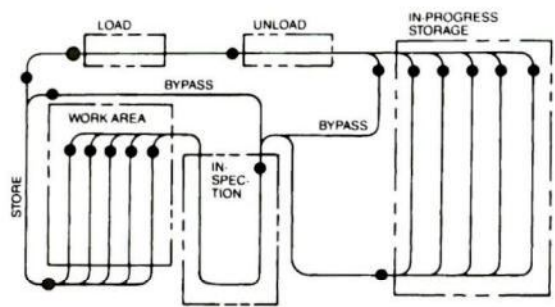

Rapid Flex™ Hand Pushed Systems

Standard components are used in the design of a handpushed enclosed track system. The addition of manual or automatic stops, tongue or box switches and lift sections can be supplied to suit any system requirement.

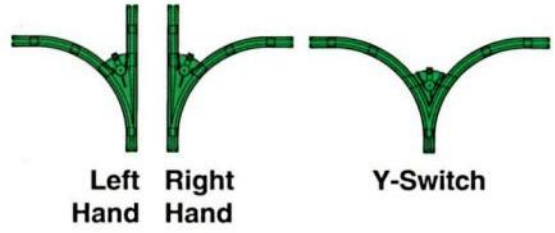

Rapid Flex™ Hand Pushed Switches

Manual or pneumatic hand pushed switches are available in above configurations with radii of 24" and 36" and degrees of 15°, 30°, 45° and 90° to suit your application.

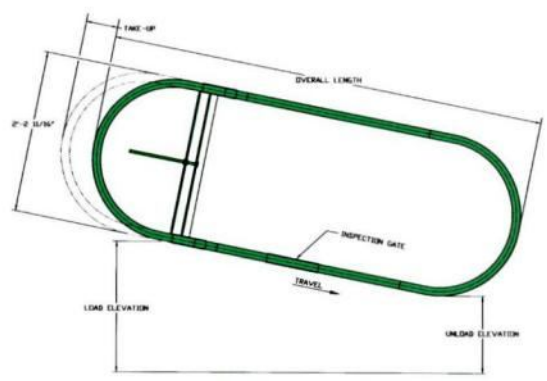

Rapid Flex™ Vertical Gravity Loop Conveyor

Components can be configured into vertical gravity loop conveyors for economical storage and transfer of goods from subassembly to main production lines.

The use of gravity keeps both price and maintenance of the units to a minimum.

These units can be pre-assembled up to 40 ft. in length.

Standard powered units can be supplied on these systems if the overall length or light product weight makes the use of gravity impractical. 180° vertical curves are available in both 12" and 24" radius.

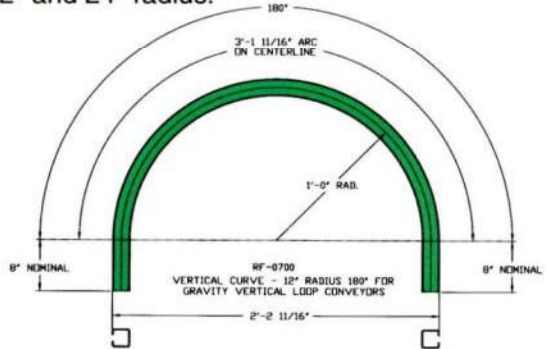

RF-0700 Vertical Curve - 12" Radius 180° Vertical Curve for Gravity Vertical Loop Conveyor

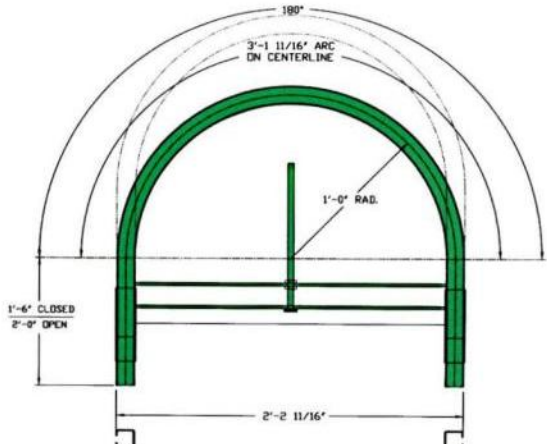

RF-0701 Vertical Curve - 12" Radius 180° Screw Type Take-Up for Gravity Vertical Conveyor

RAPID FLEX™ STANDARD COMPONENTS

Part No. Description

RF-0102	Chain Assembly - Heavy Duty
RF-0200	5/16" x 1-1/4" Clevis Pin & Safety Pin
RF-0201	"H" Attachment-Standard Duty
RF-0202	"H" Attachment - Rigid Type
RF-0203	"H" Attachment - Extended
RF-0204	Swivel Rotator
RF-0205	Swivel Rotator - 6 Point Star
RF-0206	90° Indexing Hook
RF-0207	90° Indexing Hook - 4-Point Star
RF-0300	3/8" x 1-1/4" Clevis Pin & Safety Pin
RF-0301	Load Bar
RF-0401	Horizontal Turn - 24" Radius 180°
RF-0402	Horizontal Turn - 24" Radius 90°
RF-0403	Horizontal Turn - 24" Radius 45°
RF-0404	Horizontal Turn - 24" Radius 30°
RF-0405	Horizontal Turn - 36" Radius 180°
RF-0406	Horizontal Turn - 36" Radius 90°
RF-0407	Horizontal Turn - 36" Radius 45°
RF-0408	Horizontal Turn - 36" Radius 30°
RF-0501	Vertical Curve-Upper-24" Radius 90°
RF-0502	Vertical Curve-Upper-24" Radius 60°
RF-0503	Vertical Curve-Upper-24" Radius 45°
RF-0504	Vertical Curve-Upper-24" Radius 30°
RF-0505	Vertical Curve-Upper-36" Radius 90°
RF-0506	Vertical Curve-Upper-36" Radius 45°
RF-0507	Vertical Curve-Upper-36" Radius 30°
RF-0601	Vertical Curve-Lower-24" Radius 90°
RF-0602	Vertical Curve-Lower-24" Radius 60°
RF-0603	Vertical Curve-Lower-24" Radius 45°
RF-0604	Vertical Curve-Lower-24" Radius 30°
RF-0605	Vertical Curve-Lower-36" Radius 90°
RF-0606	Vertical Curve-Lower-36" Radius 45°
RF-0607	Vertical Curve-Lower-36" Radius 30°

Part No. Description

RF-0700	Vertical Curve-12" Radius 180° Vertical Curve for Gravity Vertical Loop Conveyors
RF-0701	Vertical Curve-12" Radius 180° with Screw Type Take-Up for Gravity Vertical Loop Conveyors
RF-0702	Vertical Curve-24" Radius 180° for Gravity Vertical Loop Conveyors
RF-0703	Vertical Curve-24" Radius 180° Screw Type Take-Up for Gravity Vertical Loop Conveyors
RF-0800	Straight Track Section
RF-0900	Oven Expansion Joint
RF-1000	Chain Inspection Gate
RF-1100	Chain Installation Gate
RF-1200	Anti-Backup Stop
RF-1300	Anti-Runaway Safety Stop
RF-1402	Automatic Brush-Type Chain Oiler
RF-1403	Manual Brush-Type Chain Oiler
RF-1500	Welding Fixture
RF-1600	Take-Up Unit
RF-1601	Take-Up Expansion Joint
RF-1701	Constant Speed Caterpillar Drive Unit
RF-1702	Variable Speed Caterpillar Drive Unit
RF-1801	Rapid Flex™ Caterpillar Drive Chain
RF-1802	11 Tooth Drive Sprocket for Caterpillar Drive
RF-1803	11 Tooth Takeup Sprocket for Caterpillar Drive
RF-1804	Back-Up Bar for Caterpillar Drive
RF-1805	Torque Limitor for Caterpillar Drive
RF-1806	Caterpillar Drive Chain Dog
RF-1807	Torque Limitor Sprocket
RF-1808	Rapid Flex™ Reducer
RF-1903	Track Hanger Clamp
RF-1913	End Plate
RF-2000	250 lb. Capacity 4-Wheel Hand Pushed Trolley
RF-2100	Rapid Flex™ 4-Wheel Pusher Dog/Chain Attachment

Rapid Industries Inc. reserves the right to supply products which may differ in design from those described or illustrated in this brochure.





General Maintenance

Rapid Flex™ Overhead Enclosed Track Conveyors

After finishing mechanical installation of a Rapid Flex™ Enclosed Track Conveyor, but before system startup, adequately lubricate all moving parts. Type and quantity of lubrication depends on several factors including:

- Production/Manufacturing schedule.
- Maintenance procedures.
- Operating conditions.
- Personnel

Depending on the above factors, proper system operation requires only a minimal amount of lubricant. Over-lubrication can be as harmful as under-lubrication. Therefore, we recommend that a lubrication specialist be consulted before determining lubrication type and schedule. It may be necessary to lubricate and monitor the system regularly at the beginning, and decrease lubrication as the system matures.

Wheel bearings have a minimum amount of general purpose grease applied at the factory for initial installation. For oven application with temperature above 250° F, install an automatic lubricator at the exit end of the oven. Locate the lubricator far enough from the exit of the oven to allow for the chain to cool to approximately 200° F before applying lubricant. To keep contamination down, the lubricator should apply a minimal amount of oil to the wheel bearings and chain pins. Consult a lubrication specialist for the proper amount of lubricant.

Check the chain wheels to ensure proper rotation and the chain so it is not dry. Replace sluggishly rotating or frozen chain wheels immediately. Never attempt to repair any chain parts damaged during operation. Replace the damaged section with new chain.

Rapid Flex™ drive units are supplied with either a torque limiter device or an electrical overload safety cutoff. Slippage of the torque limiter device or overload cutoff indicates excessive chain pull in the system. Causes may be either a possible lack of chain lubrication or an overloaded system. Check the chain for lubrication and the chain pull for the possible need for the addition of another drive.

Inspect the Rapid Flex™ conveyor regularly for proper lubrication and wear. We recommend keeping detailed records of conveyor maintenance and chain lubrication.

Keep records of the following:

- Inspection date.
- Inspection result.
- Repairs
- Parts replaced.
- Cause of problems.
- Signature of inspector.

CAUTION: Never operate a Rapid Flex™ conveyor without properly lubricating the chain. Rapid Flex™ RF-1402 and RF-1403 brush oilers usually supply sufficient lubrication to chain operating in applications with temperatures under 250° F. When operating temperatures which exceed 250° F, an automatic chain lubricator is preferred.

MAINTENANCE AND TROUBLESHOOTING

Following are suggestions on general and preventive maintenance procedures and troubleshooting that will improve efficiency and life of operation of a Rapid Flex™ conveyor.

IMPORTANT:

Review the following procedures before conveyor maintenance and/or adjustments. Turn off the drive and lock out all power before performing any inspection, testing, maintenance or repairs on the conveyor. Remove all safety barriers and equipment before restarting the conveyor.

CAUTION:

Unaware personnel, not warned of conveyor startup, are at risk of injury.

THE SIGNIFICANCE OF THE RF-1000 INSPECTION GATE

Rapid recommends that a RF-1000 Inspection Gate be installed every 300 to 400 feet along the conveyor system. Inspection gates allow maintenance personnel to view the chain and examine:

- The overall lubrication of the chain
- The operating state of the wheel bearings, chain pins and side links
- The chain stress (too extreme vs. too loose)
- Undesired residue, dirt or contamination on the chain
- The overall state and functioning efficiency of the conveyor

RF-1000 INSPECTION GATE

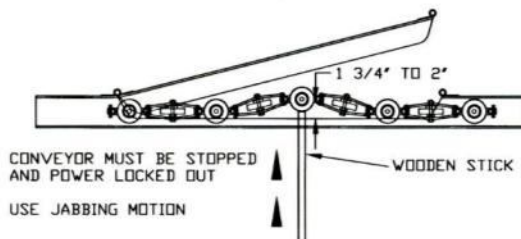

Some chain slack is preferred to no slack at all. Enough slack to raise the chain 1-3/4 inches to 2 inches suggests appropriate tension.

PREVENTIVE MAINTENANCE SCHEDULE

To help promote efficiency and reliability of a Rapid Flex™ conveyor, Rapid Industries, Inc. suggests adhering to a timely and proper maintenance inspection schedule. Failure to perform proper preventive maintenance can result in production, manufacturing or finishing system downtime. Keep a timely scheduled inspection list that includes the date of inspection, result of findings, cause of any findings, repairs completed and parts replaced. Following is an inspection check list covering items to be reviewed during the inspection of the conveyor.

INSPECTION CHECKLIST

1. Conveyor Chain
 - A. Over/Under lubrication
 - B. Excessive wear
 - C. Chain looseness or extreme tension
 - D. Chain surge
 - E. Slow or motionless wheel rotation
 - F. Bent or damaged chain links
 - G. Loose axle bolts
 - H. Loose load and guide wheels
 - I. Loose wheel bearings
2. Take-up
 - A. Track wear
 - B. Travel extension
 - C. Proper spring or air cylinder tension
 - D. Expansion joint status:
 - a. Lubrication
 - b. Wear
 - c. Movement
 - E. Floating frame travel operation
3. Conveyor Track
 - A. Vertical curve flange wear
 - B. Flange wear at load/unload areas
 - C. Wear on the inside radius of horizontal turns
 - D. Obstructions interfering with conveyor or product movement
 - E. Inadequate sway bracing to stabilize the conveyor
4. Drive
 - A. Lubrication
 - a. Cat chain
 - b. Machine components
 - c. Bearings
 - d. Reducer oil level
 - B. Wear
 - a. Cat chain
 - b. Backup bar
 - c. Sprockets
 - d. Wiring insulation
 - C. Adjustment
 - a. Take-up unit
 - b. Operating temperature of motor/reducer
 - D. Overload state
 - a. No torque limiter slippage
 - b. Test overload limit switch to assure drive cutoff
 - c. Operating temperature of motor/reducer
 - E. Minimal reducer oil leakage
 - F. No loose mounting bolts
 - G. Track bar distortion caused by conveyor jam-up
 - H. Strange sounds
5. Anti-backups
 - A. Pivot point lubrication
 - B. Free movement
 - C. Wear
6. Anti-runaways
 - A. Pivot point lubrication
 - B. Test limit switch to assure drive cutoff



Troubleshooting

PROBLEM	POSSIBLE REASON	POSSIBLE CURE
Track		
1. Vertical curve flange damage	Extreme chain stress	Adjust take-up unit
2. Extreme flange wear	Slow rotating or motionless wheels	Replace chain section
3. Horizontal turn wear on inside radius	Extreme chain stress	Adjust take-up
	Slow rotating or motionless horizontal guide wheels	Replace chain section
Take-Up		
1. Difficult or no travel movement	Non-lubricated expansion joints	Lubricate
	Impaired expansion joint	Replace with new
	Extreme chain stress	Adjust take-up
	Slow rotating or motionless take-up wheel	Clean and replace
Chain		
1. Extreme wheel & pin wear/extreme chain stress	Inadequate lubrication	Lubricate wheel bearings and chain pins
	Slow rotating or motionless wheels	Replace chain section
	Chain travel interference	Identify and remove interference
	Overloaded conveyor	Conveyor will operate for a short period but not continuously, eliminate overload
	Excessive chain tension	Inspect take-up spring or air cylinder for excessive pressure
2. Too much chain slack	Normal chain wear	Pull-in take-up and remove chain section
3. Conveyor surge	Too much chain slack	Adjust take-up (see above)
	Slow rotating or motionless wheels	Replace chain section
Drive		
1. Conveyor speed reduction	Torque limiter slippage	Replace friction discs
	Loose screws on sprocket	Adjust sprocket/secure screws
	Excessive chain pull	Adjust take-up
2. Irregular reducer noise	Under-lubricated	Add oil to reducer
	Oil leakage	Tighten bearing caps/pipe plugs and add lubricant
	Excessive gear wear or damage	Replace gear or reducer
3. Drive operation halted	Torque limiter	If slippage is occurring replace discs at proper tension
4. Excessively high motor temperature	Extreme chain pull	Check wiring and controls
5. Surging cat chain	Loose chain	Adjust drive take-up to proper tension
	Excessive cat chain dog wear	Replace cat chain